

# ZINC DIE-CAST LIQUID TIGHT CONDUIT CONNECTORS

(TESTED AND CERTIFIED TO U.S. AND CANADA STANDARDS)



## FEATURES:

- Available 3/8" though 4"
- For use with both Metallic Liquid Tight Conduit and Nonmetallic Liquid Tight Type B
- Zinc construction resists salt water, weak acids, gasoline, alcohol, oil grease & common solvents
- Resistant to outdoor weather conditions
- No disassembly required
- No threading of the conduit or tubing required
- Complete conduit/connector system is reusable
- Suitable for indoor/outdoor use; for original equipment manufacturers or field installers
- Smooth internal surfaces
- "O" Ring & zinc locknut included
- RoHS WEEE compliant

## Straight Connectors

| Item No. | Trade Size | K.O. Size | Pkg Qty | Weight Per Pkg | Part Dimensions (inches) |       |       |
|----------|------------|-----------|---------|----------------|--------------------------|-------|-------|
|          |            |           |         |                | A                        | B     | C     |
| 5800-SF  | 3/8"       | 1/2"      | 100     | 18             | 1.58"                    | 1.18" | 0.53" |
| 5801-SF  | 1/2"       | 1/2"      | 100     | 18             | 1.58"                    | 1.18" | 0.53" |
| 5802-SF  | 3/4"       | 3/4"      | 100     | 23             | 1.69"                    | 1.57" | 0.58" |
| 5803-SF  | 1"         | 1"        | 25      | 10             | 2.06"                    | 1.81" | 0.58" |
| 5804-SF  | 1-1/4"     | 1-1/4"    | 25      | 15             | 2.06"                    | 2.18" | 0.61" |
| 5805-SF  | 1-1/2"     | 1-1/2"    | 10      | 7.5            | 2.09"                    | 2.51" | 0.63" |
| 5806-SF  | 2"         | 2"        | 10      | 12             | 2.15"                    | 3.03" | 0.63" |
| 5807-SF  | 2-1/2"     | 2-1/2"    | 5       | 7.5            | 3.54"                    | 3.68" | 1.02" |
| 5808-SF  | 3"         | 3"        | 1       | 2              | 4.04"                    | 4.38" | 1.07" |
| 5810-SF  | 4"         | 4"        | 1       | 4              | 4.99"                    | 5.54" | 1.15" |

## 90 Degree Connectors

| Item No. | Trade Size | K.O. Size | Pkg Qty | Weight Per Pkg | Part Dimensions (inches) |        |       |
|----------|------------|-----------|---------|----------------|--------------------------|--------|-------|
|          |            |           |         |                | A                        | B      | C     |
| 5800-EL  | 3/8"       | 1/2"      | 100     | 27             | 2.11"                    | 2.53"  | 0.53" |
| 5801-EL  | 1/2"       | 1/2"      | 100     | 28             | 2.24"                    | 2.46"  | 0.53" |
| 5802-EL  | 3/4"       | 3/4"      | 100     | 38             | 2.47"                    | 2.79"  | 0.55" |
| 5803-EL  | 1"         | 1"        | 25      | 16             | 3.46"                    | 3.86"  | 0.58" |
| 5804-EL  | 1-1/4"     | 1-1/4"    | 25      | 25             | 3.37"                    | 3.99"  | 0.67" |
| 5805-EL  | 1-1/2"     | 1-1/2"    | 10      | 13             | 4.28"                    | 5.04"  | 0.61" |
| 5806-EL  | 2"         | 2"        | 10      | 19             | 4.21"                    | 5.06"  | 0.71" |
| 5807-EL  | 2-1/2"     | 2-1/2"    | 1       | 4              | 5.75"                    | 7.00"  | 1.03" |
| 5808-EL  | 3"         | 3"        | 1       | 5              | 6.00"                    | 7.25"  | 0.99" |
| 5810-EL  | 4"         | 4"        | 1       | 7              | 8.75"                    | 10.00" | 1.17" |

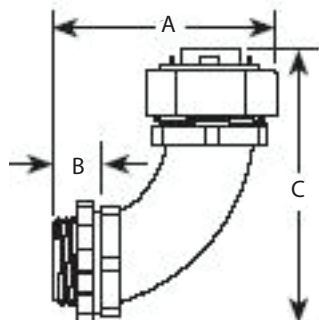
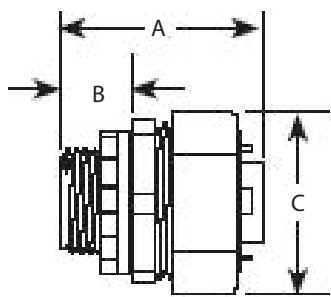

**INTERNATIONAL**  
METAL HOSE COMPANY

QUALITY MATERIALS • QUALITY MANUFACTURING  
QUALITY PERFORMANCE

520 Goodrich Road – Bellevue, OH 44811-0149 – Phone: 419.483.7690  
Fax: 419.483.8225 – Toll Free: 800.458.6855 – www.metalhose.com